

Ball Mill Oxide Systems

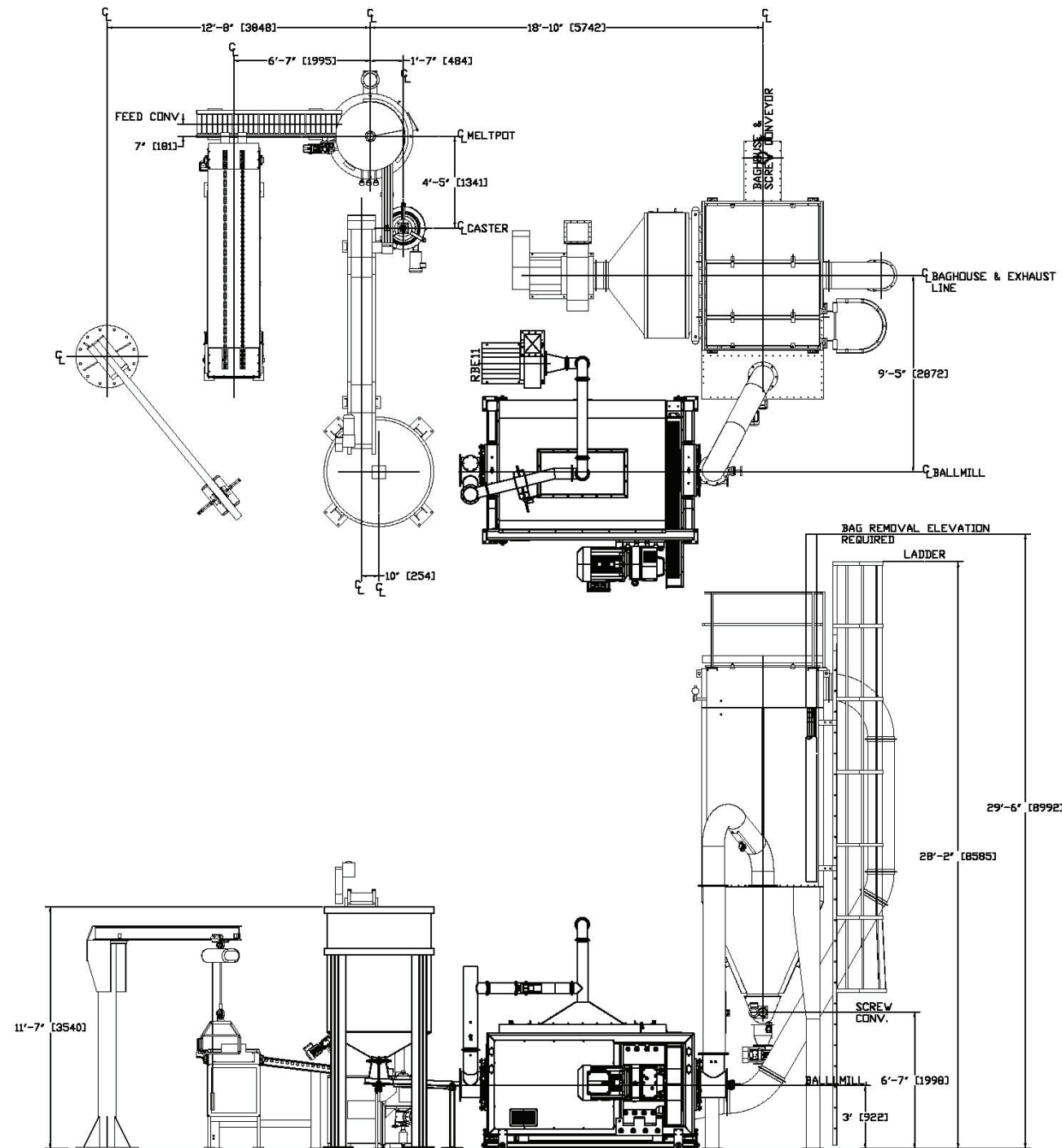

Ball Mill Oxide Systems



Three sizes to choose from: 8 ton, 15 ton, & 25 Ton

- Flexible control of oxide specifications
- Oxide recycle hopper on inlet
- Maximum reaction control and data logging using PLC/PC
- Design simplicity provides for ease of operation and maintenance
- Custom engineered for each application

As the lead cylinders are tumbled inside of the ball mill, they oxidize on their surface to lead oxide. The oxide particles abrade off the cylinders and are milled by the tumbling action of the mass.

Friction between the cylinders creates heat that initiates the oxidation process, then after the oxidation process is established, a large amount of heat is generated by the exothermic reaction of lead converting to lead oxide. Exothermic heat raises the temperature of the mass of material in the mill which accelerates the oxidation process.

A draft of air through the mill carries the **Battery Oxide** out of the mill and into the collection system. Heavier particles remain in the mill until they are small enough and light enough to be carried by the air.

The collection system baghouse is fitted with high temperature, membrane coated, filter bags that hang vertically and are cleaned with a pulse of compressed air. Oxide is deposited in an oversized baghouse hopper and continuously discharged through a screw conveyor and rotary air lock. From here, the **Battery Oxide** can be transported to a storage tank using any of several conveying methods.

Air exhausting from the baghouse passes thru a HEPA filter before exhausting the system, assuring that the system meets strict environmental regulations.

Ball Mill for Battery Oxide:

The Eagle Ball Mill Oxide Systems have been developed to produce a high quality **Battery Oxide** to demanding specifications for use in lead acid batteries.

Eagle's Ball Mills have mechanical features and a PLC based control system that automatically maintain operating conditions in the ball mill that directly affect important **Battery Oxide** characteristics such as; PbO/PbO ratio, particle size, and surface texture.

Battery Oxide is a type of *Leady Oxide* that has portions of its material as non-reacted free metal lead (Pb) and lead oxide (PbO).

System Operation:

Lead ingots are melted in a melting pot. Molten lead is pumped to a water cooled casting machine that casts small cylinders of lead. The cylinders are transported to a surge tank where an appropriate inventory is maintained.

Cylinders are weighed and metered into the rotating drum of the ball mill at a rate that matches the production rate of oxidation process.

PLC Monitoring/Control:

Ball Mill control systems allow the operator to independently monitor and control the oxidation process. Critical operating conditions are measured by sensors located at several locations along the process. Data is analyzed by a central PLC that automatically maintains optimum conditions for a steady reaction.



System Manufacturers:
Eagle Oxide Services
Indianapolis, Indiana USA

Helping to make the best batteries...yours.

Sales Agent:

MAC Engineering and Equipment Company, Inc.
2775 Meadowbrook Road, Benton Harbor, Michigan 49022, U.S.A.
Telephone: (269) 925-3295 or 1-800-756-8608 Fax: (269) 925-3305
e-mail: maceng@mac-eng.com
For a preview of our equipment visit: www.mac-eng.com



The three most important PID loop functions automatically react to and control:

1. **Temperature** of the reacting oxide mass.
2. **Weight** of the oxidizing mass in the mill.
2. **Draft** of air through the ball mill.

Alarms, an automatic cool down procedure, and an emergency shut down sequences allows the system to operate with a high level of security. Operating data and alarms are logged and down-loaded to electronic files. *Real Time* and *Historical* trending charts graphically display essential data that help the operators and process engineers adjust the system for optimum performance.

Controls description:

Temperature Sensing/Control:

The system temperature profile is monitored using 19 thermocouples and sensors;

Load and Level Sensing/Control:

Load cells monitor material load in several key components and provide this information to the PLC for process control and inventory evaluation:

Airflow and Pressure Sensing/Control:

Air flow through the ball mill is the most critical component of producing high quality **Battery Oxide**. Airflow volume and static air pressure readings are monitored with various sensors throughout the system.



CONNECTED ENERGY VALUES

EQUIPMENT	MAXIMUM CAPACITY
Lead Melt Pot Heat	Natural Gas 200,000 kilocalories
Lead Line Heat	Electric 6 kilowatts
Electric Motors	<u>Hp / kW</u>
Combustion Blower	.75 / .55
Lead Pump *	1.5 / 1.1
Cylinder Caster *	1 / .75
Elevator	1.5 / 1.1
Feed Conveyor	1 / .75
Ball Mill *	150 / 111
Oil Pump #1	.5 / .37
Oil Pump #2	.5 / .37
Oil pump #3	.5 .37
Shell cooling fan*	5 / 4
Exhaust Fan *	25 / 18.5
Baghouse Conveyor	3 / 2.2
Rotary Air lock	1 / 0.75
* VFD Speed Control	

PRODUCTION RATE

Ball Mill M8: up to 8 tons per day
Ball Mill M15: up to 15 tons per day
Ball Mill M25: up to 25 tons per day

OXIDE SPECIFICATIONS

OXIDE SPECIFICATION	UNITS	RANGE
PbO	Percent	75 to 65
Pb	Percent	25 to 35
Apparent density	grams / cm ³	1.2 to 1.8
Acid absorption	milligrams / gram	240 to 280
Tetragonal crystal of PbO	Percent	99
Particle size	median micron	2.0 to 3.0